

# 4302D 16:9 PCAP

Digital Signage Touch Monitor



## Features

- + Metal shell material, flat, ultra-light and thin
- + Front frame against dust and liquids
- + Integrated back reinforcement structure
- + Commercial grade LCD, LED backlight
- + Resolution 1920X1080FHD@60Hz
- + 450nits brightness, full viewing angle
- + 50,000 hours of backlight lifespan
- + 10-touch projective capacitive touchscreen
- + 7H physical tempered glass, surface AF coating
- + Smooth to the touch, even with water droplets.
- + The touchscreen uses a USB control interface
- + Supports both landscape and portrait orientations
- + Video interface : HDMI+VGA
- + Back VESA wall mounting : 400X400mm
- + Support OS: Windows/Android/Linux
- + 2-Year Warranty



## Optional:

- No touch
- AG coating
- Display Port
- Media play
- All-in-one (Android /Windows)



## TDS4302D Digital Signage Touch Monitor Specification

Model	4302D(4302C)
Color	Black
Diagonal	43"
Aspect ratio	16:9
Active area	940.2X529.4 (mm)
Dimensions	984.4X578.3X58.5(mm)
Resolution	1920X1080FHD@60Hz
Viewing Angle	Horizontal: 89°/89°, vertical: 89°/89°
Number of Colors	16.7 M
Brightness	LCD panel: 450cd/m <sup>2</sup> ;Touch:415cd/m <sup>2</sup>
Contrast	1200:1
Response time	8ms
Touch technology	Projective capacitive -10 touch
Input method	Finger, Capacitance pen Latex gloves touch (Thickness ≤ 2mm )
Light transmittance	90%
Surface hardness	7H
Touch Interface	USB2.0
Video Interface	HDMI+VGA
Speaker	TwoX2W internal speakers
Input voltage	AC: 100-240 VAC,50/60 Hz
Power type	Built-in AC
Sealability	Touchscreen sealed to bezel
Drop test	Withstand drop test of a 500g steel ball from a height of 1.2 meters.
Weight(Unpackage)	15.5KG
Shipping Dimensions	1090X150X710(mm)
Temperature	Operating: 0°C-40°C; Storage-20°C-60°C
Humidity	Operating: 20% to 70%; Storage: 10% to 80%
Power consumption	ON: 90W, SLEEP: 1.2W
Mounting Options	VESA 400X400(mm),M6
MTBF	50000 hours
Warranty	2-year
Agency Approvals	FCC; CE; ROHS
Support OS	Windows/Linux\Android
What's in the Box	1*HDMI cable /1*USB cable /1*AC cable/1*Remote control Wall mount bracket(Optional)

# TDS4302D-PCAP

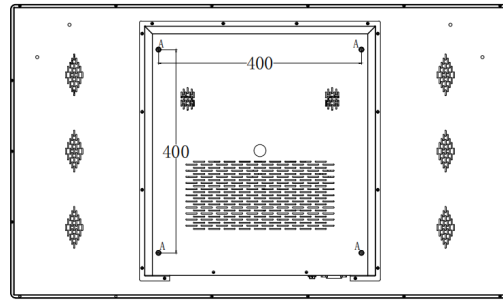
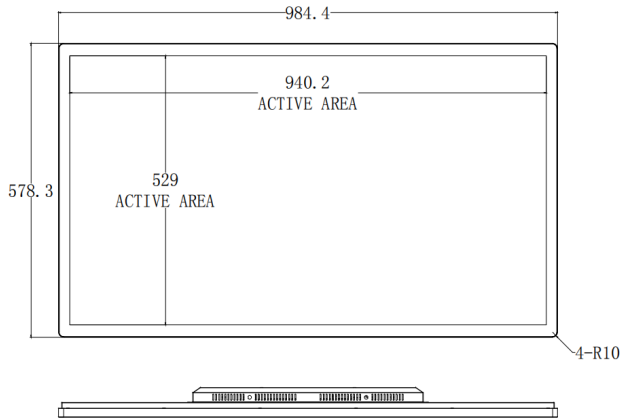

A:M6 THREADS, X4 MAX SCREW DEPTH=8MM FROM MOUNTING SURFACE

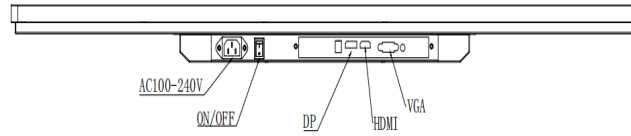
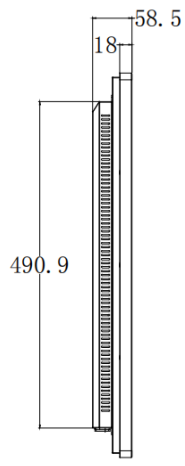

Dimensions are in millimeters

